

# IMPLANT LINE BT KONIC



GUIDELINES FOR THE USE  
OF BT KONIC  
IMPLANT SYSTEM

## **IMPORTANT NOTE**

For latest updates and information, visit **[www.btk.dental](http://www.btk.dental)**

This manual provides dental practitioners and related specialists with general information regarding the use of BT KONIC dental implant systems.

For detailed information on other specific implant lines and their restorative procedures, please refer to the corresponding manuals, specific literature or refer to the BTK website.

Consider to regularly visit practical courses for updates and professional exchange with dedicated colleagues in order to ensure your long-term success with implant-borne dental restorations.

© 2019 BTK - the smile system.

# BT KONIC

THE ANATOMICAL IMPLANT LINE,  
SUITABLE IN POST-EXTRACTION SITES  
AND FOR LOW DENSITY BONE



# INDEX

1.	CORPORATE BACKGROUND	6
2.	IMPLANT SELECTION	8
3.	IMPLANT CHARACTERISTICS	10
4.	IMPLANT PORTFOLIO	12
5.	IMPLANT INSERTION PROCEDURE	14
6.	KIT, TORQUE WRENCH AND DRILLS	16
7.	SURGICAL PROTOCOLS	20
8.	SURGICAL INSTRUMENTS	22
9.	INTERNAL HEXAGON (INT) IR/IW	26
10.	EXTERNAL HEXAGON (EXT) EN/ER/EW	32
11.	OVERDENTURE	38
12.	MATERIAL SPECIFICATIONS	40
13.	LABELS SYMBOLS	42
14.	DELIVERY TERMS AND CONDITIONS	43

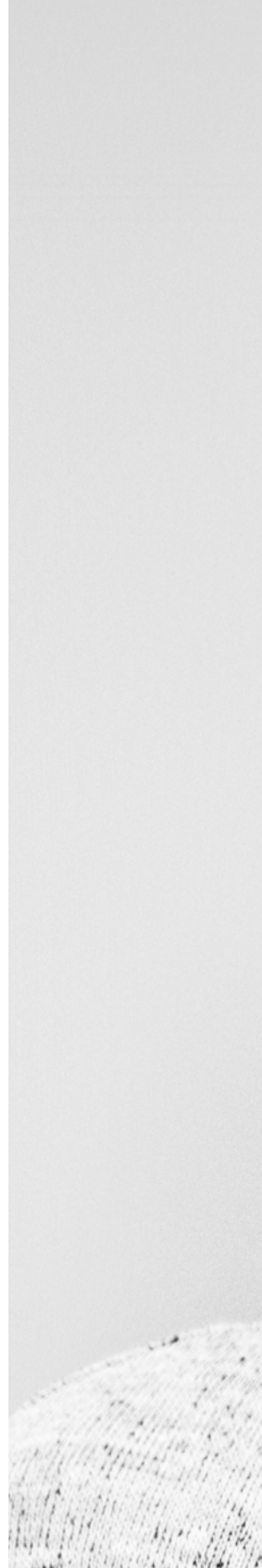



## CORPORATE BACKGROUND

Privately held BTK BIOTEC was founded in 1998 in order to improve the quality of life of people with missing teeth.

BTK is a dedicated supporter of the genuine "100% Made in Italy" label, because with this it is guaranteed that BTK products are of unmatchable Italian craftsmanship and premium quality materials offering dedicated specialization and ample differentiation.



BTK Headquarters - NORTH ITALY

## Implanting Trust, Smile again!

By combining cutting-edge technologies and biology, BTK's mission is to offer affordable and personalized implant-borne solutions thereby sustainably improving the daily life of dental patients.

**Together with leading professionals, BTK strives to become a reference in replacing missing teeth with trusted implant solutions in order to improve oral health around the globe.**





### PREMIUM QUALITY MATERIALS

Grade 4 commercially pure titanium (ASTM F 67 / ISO 5832-2) is BTK's material of choice for dental implants. Grade 4 is slightly harder to work, but it provides the highest strength and durability characteristics among the commercially pure titanium grades, making it the natural choice for BTK dental implants.

Grade 5 titanium (ASTM F 136 / ISO 5832-3) is used for BTK's prosthetic components, as these are subject to certain levels of stress and in the MINI line implants. This high-strength version, also known as Ti-6Al-4V, is widely used in orthopedics and shows excellent long-term physical and mechanical properties.

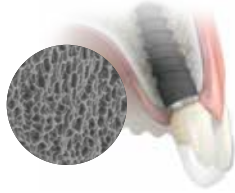

### ENDOSSEOUS SURFACE DAE

Clinical trials confirm that roughened endosseous surfaces perform better than machined surfaces concerning endosseous wound healing, "de novo" bone formation and reduced time-to-loading.

Our DAE (dual- acid-etched) process aims to obtain a moderately rough surface with a controlled micro-roughness.



### IMPLANT-ABUTMENT CONNECTION

The precision of the connection between implant and abutment creating a tight seal may be beneficial in preventing inflammatory bacteria propagating in the interface between different components.

Apart from that, extremely tight tolerances as applied by BTK help to avoid micromovements.

Providing precision in every part produced is one of our key contributions ensuring longterm restorative success.



### RESTORATIVE OPTIONS

The purpose of dental implant therapy, now widely used in dentistry, is to replace lost dental elements with biocompatible titanium implants, in order to obtain a new and correct occlusion, using prostheses on implants.

In order to achieve this goal, BTK offers a focused portfolio of restorative solutions backed-up by comprehensive clinical experience. BTK offers a variety of prostheses components to satisfy the clinical preferences and needs of the patients.



### MADE IN ITALY, USED GLOBALLY

We constantly ensure that the quality of our products and services meet the high expectations of our customers and their patients. Specialized professionals are taking care to offer comprehensive solutions in applied research, engineering, education and related activities.

Our brand is a solid promise of quality, we are certified UNI EN ISO 9001, UNI EN ISO 13485 and MDD 93/42/EEC and subsequent amendments and additions, and is therefore authorized to apply the CE Mark on its products.

## IMPLANT PORTFOLIO

BTK is dedicated to offer comprehensive implant solutions to meet the requirements of individual clinical situations, user preferences and economic constraints.

Different designs, sizes, diameters, surfaces and abutment connections are available, while at the same time BTK strives to maintain a small number of precision-instruments thus simplifying procedures and limiting investments needed.



## SELECTION OF THE IMPLANTS ON THE BASIS OF BONE DENSITY AND OF THE DRILLING PROTOCOL

### IMPLANT DESIGN

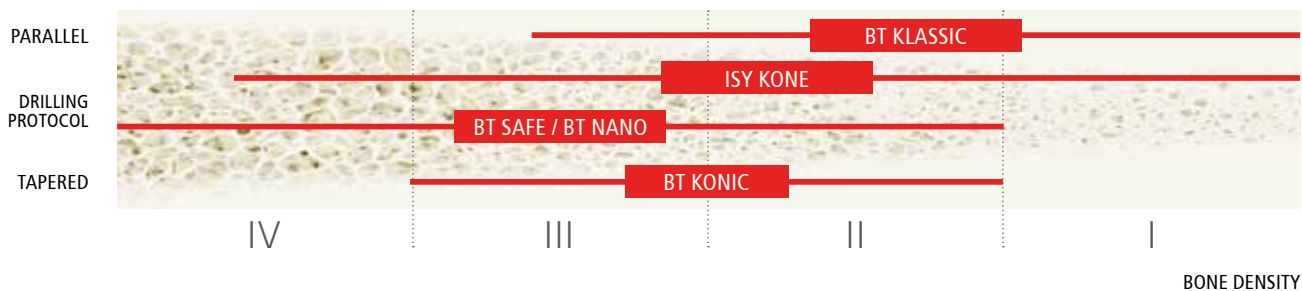



# CHARACTERIZATION OF BTK IMPLANT-ABUTMENT CONNECTIONS



## MORSE-TAPER (MTH)

**BTK's morse-taper hexagon connection** comprises a 2.6 mm conical portion at 11° above a hexagon configuration combined with a M1.6 (KR) or M1.8 (KW) abutment screw to deliver adequate pre-load with a minimum of tightening.

Implants with a tapered interface can resist larger axial and transversal forces than implants with a flat interface. The design guides the abutment into a predictable location with a precise fit with the inner portion of the implant.

The precision of the conical connection with its tight seal may be beneficial in preventing inflammatory bacteria from propagating in the interface between implant and abutment and it helps to avoid micro-movements.

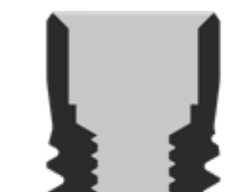

## INTERNAL HEXAGON (INT)

**BTK's internal hexagon connection** comprises a parallel hexagon of 2 mm length opening with a small conical portion combined with a M1.8 abutment screw to deliver adequate pre-load with a minimum of tightening.

The internal hexagon has two functions: to transfer the torque momentum during implant placement and as an indexing system to transfer the precise 3D-position of the implant to the master cast.

Internal indexing systems have some advantages over external indexing systems since they allow longer engaging surfaces while reducing the platform height of the implant. This offers somewhat more flexibility in designing the emergence profile of the final restoration.



## EXTERNAL HEXAGON (EXT)

**BTK's external hexagon connection** comprises a parallel hexagon at 0.7 mm height and a 90° shoulder to allow a flat-to-flat margin fit to the implant. Abutments are connected to the implant using a M1.8 (EN) or M2.0 (ER/EW) abutment screw.

The abutment screw plays a central role for the mechanical, long-term strength and fatigue resistance of the implant abutment connection. The requirements for such a screw are many, such as no loosening, long-term fatigue resistance, overload protection and safe pick-up and handling ability.

Due to the fact that the abutment screw is exposed to heavy dynamic loads, the precise application of tightening torque force is essential.

MORSE-TAPER (MTH)	INTERNAL HEXAGON (INT)	EXTERNAL HEXAGON (EXT)
		<b>EN</b> = EXTERNAL NARROW
<b>KR</b> = KONIC REGULAR	<b>IR</b> = INTERNAL REGULAR	<b>ER</b> = EXTERNAL REGULAR
	<b>IM</b> = INTERNAL MEDIUM	
<b>KW</b> = KONIC WIDE	<b>IW</b> = INTERNAL WIDE	<b>EW</b> = EXTERNAL WIDE

**NOTE** that different BTK implants require different types of prosthetic platforms using corresponding abbreviations according to their sizes. For more details, refer to the corresponding BTK implant lines documentation.

3. IMPLANT CHARACTERISTICS

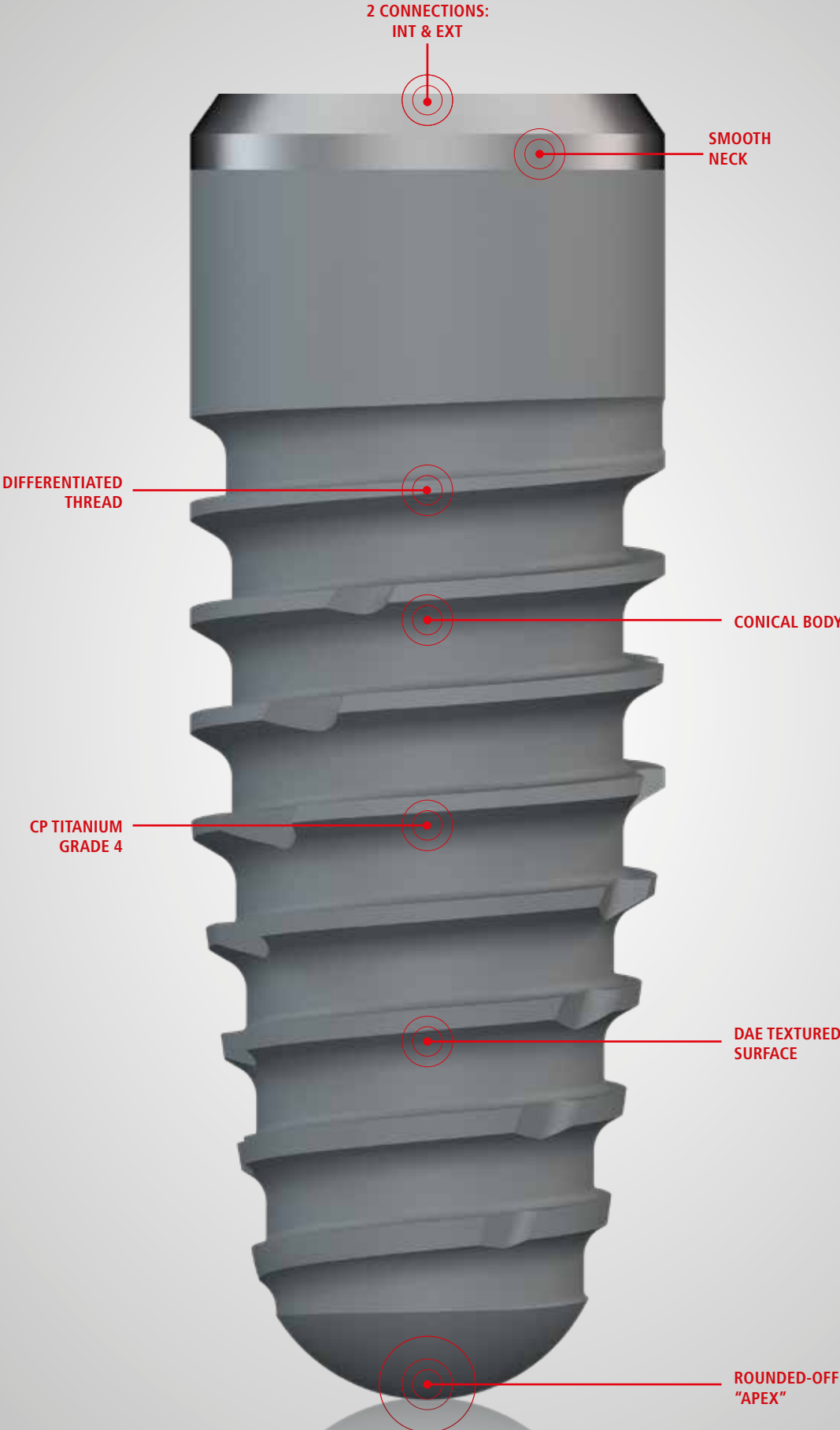

## THE ANATOMICAL IMPLANT LINE, SUITABLE IN POST-EXTRACTION SITES AND FOR LOW DENSITY BONE

BT KONIC is a bone-level implant which replicates the root of the natural tooth and has a smooth parallel collar portion between 1.0 mm (INT) and 1.2 mm (EXT): it is particularly suitable for classic two-stage procedures, in which the implant is positioned at the bone level and submerged by the surrounding soft tissue during the healing phase (healing in two stages). BT KONIC adopts an internal (INT) or external (EXT) hexagon connection with corresponding narrow (EN), regular (IR / ER) and wide (IW / EW) prosthetic components.

The pitch of the V-shaped thread in BT KONIC is 0.8 - 0.9 mm depending on the diameter / connection.

BT KONIC is an implant line that meets several surgical needs thanks to its simplicity of use and its reliability. The implant is particularly used in bone with a medium-low density, for single or multiple restorations on frontal or posterior teeth by preferentially deferred loading protocol. Restoration components include single crowns and partial or complete dentures, connected to the BT KONIC implants by means of the corresponding abutments or customized devices.

BT KONIC dental implants are produced using cold-worked commercially pure titanium (grade 4); implants are featured by a DAE surface (Double Acid Etching treatment). The design of the implant collar has been designed to ensure compliance with surrounding soft tissue and the biological width. In its internal hexagon version (INT), the BT KONIC implant has a coronal shape which, associated with the prosthetic components, allows a moderate platform shifting.

Shape and pitch of the thread, such as the conical design of the body, allow to use the implant in different types of surgical procedures and rehabilitation especially when low density bone is present. The body design of BT KONIC allows to compact the alveolar bone during the insertion, thus obtaining high levels of primary stability. The implant is particularly suitable in case of post-extraction sites because its shape simulates the root anatomy of the extracted tooth.

The rounded shape of the apical part of BT KONIC is ideal for easily directing the implant during the insertion or in case of non-invasive surgery, allowing for example to perform maxillary sinus lift procedures. Finally, the longitudinal milling along the implant body increases the mechanical anchoring of the implant to the bone.

# IMPLANT PORTFOLIO

## BT KONIC

INTERNAL HEXAGON CONNECTION IR / IW	implant length in mm <b>B</b>						APEX TIP ∅ / mm <b>D</b>
	∅ mm <b>A</b>	8,5	10	11,5	13	15	
 INTERNAL HEXAGON (IR) <b>C</b>	<b>IR (internal regular)</b> M1.8 Occlusal thread / Prosthetic platform ∅ 3.5 mm / Smooth neck portion 1 mm						
	3,25	-	108IR32L	108IR32M	108IR32P	108IR32R	1.8
	4	108IR40J	108IR40L	108IR40M	108IR40P	108IR40R	2.5
INTERNAL HEXAGON (IW) <b>C</b>	<b>IW (internal wide)</b> M1.8 Occlusal thread / Prosthetic platform ∅ 5.0 mm / Smooth neck portion 1 mm						
	5	108IW50J	108IW50L	108IW50M	108IW50P	108IW50R	3.2

EXTERNAL HEXAGON CONNECTION EN / ER / EW	implant length in mm <b>B</b>						APEX TIP ∅ / mm <b>D</b>
	∅ mm <b>A</b>	8,5	10	11,5	13	15	
 EXTERNAL HEXAGON (EN) <b>C</b>	<b>EN (external narrow)</b> M1.8 Occlusal thread / Prosthetic platform ∅ 3.4 mm / Smooth neck portion 1.2 mm						
	3,25	-	107EN32L	107EN32M	107EN32P	107EN32R	1.8
EXTERNAL HEXAGON (ER) <b>C</b>	<b>ER (external regular)</b> M2.0 Occlusal thread / Prosthetic platform ∅ 4.1 mm / Smooth neck portion 1.2 mm						
	4	107ER40J	107ER40L	107ER40M	107ER40P	107ER40R	2.5
EXTERNAL HEXAGON (EW) <b>C</b>	<b>EW (external wide)</b> M2.0 Occlusal thread / Prosthetic platform ∅ 5.0 mm / Smooth neck portion 1.2 mm						
	5	107EW50J	107EW50L	107EW50M	107EW50P	107EW50R	3.2

**INTERNAL HEXAGON  
CONNECTION  
IR / IW**

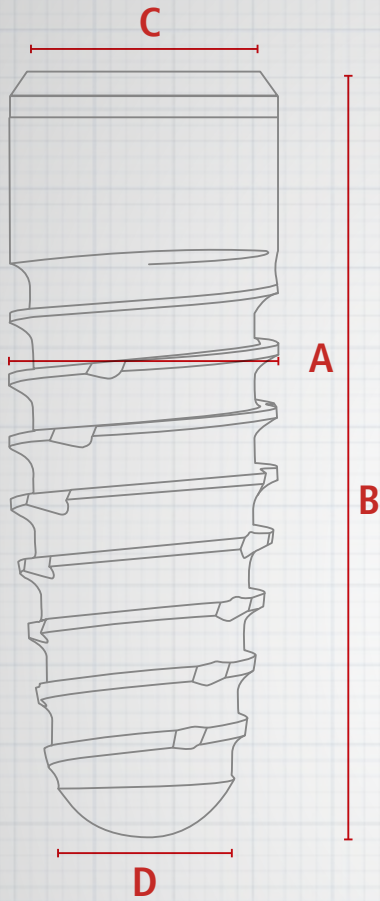

**EXTERNAL HEXAGON  
CONNECTION  
EN / ER / EW**

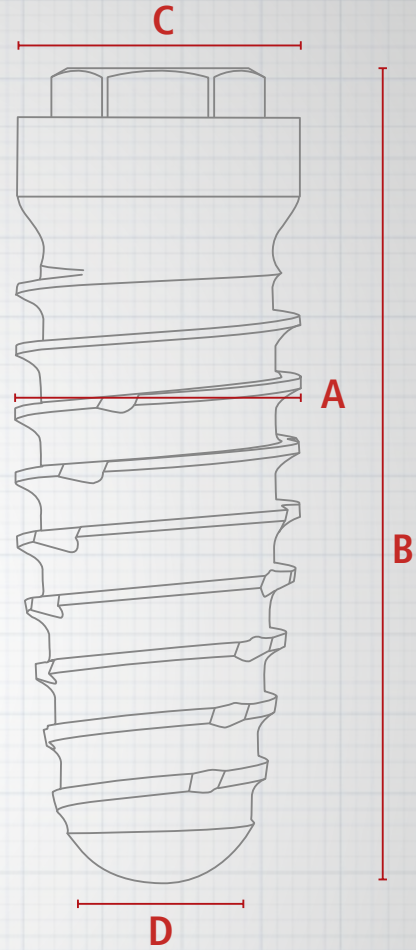

The color codes applied for different implant diameters and prosthetic platforms are indicated below:

	PURPLE	BLUE	YELLOW
IMPLANT DIAMETER Ø	3,25	4	5
PROSTHETIC PLATFORM INT	IR	IR	IW
PROSTHETIC PLATFORM EXT	EN	ER	EW



## HANDLING OF STERILE IMPLANT PACKAGING

### CAUTION

The sealed package of the medical device (MD) must be opened in a surgically suitable environment.

The removal of the implant and of the cover screw, if provided, must be carried out using sterilized instruments, avoiding any contact with non-sterile surfaces.

The sterility of the medical device is only guaranteed if the following conditions are met:

the expiry date stated on the packaging is still valid; there is a red dot on the sterile vial that signals the successful operation of gamma ray irradiation; the sealed package has not been opened and does not show damage or perforations. If only one of the aforementioned conditions is not respected, the device must not be used.

The device is disposable; the reuse can compromise the safety features of the device making it inappropriate for its intended use. BIOTEC explicitly declares that the MD is for single use and assumes no responsibility for any re-use by users.



1

BTK dental implants are supplied sterile in a double-vial package. The implant diameter, length and lot are shown on the label located in the vial containing the implant and in the outer label on the back of the packaging.



2

Open the blister from the back by breaking the outer label, and take out the vial.



3

The top lid of the vial is protected by the seal label. The color of the seal label identifies the diameter of the implant. To facilitate compliance with the traceability requirement of the medical device, there are two detachable patient-labels in the vial. One must be stuck onto the patient's medical record and one onto the patient's implant passport.



4

Open the external vial and withdraw the internal vial containing the implant in a surgically suitable environment. The internal vial must be handled with sterile gloves.



5

Remove the safety cap of the sterile inner vial, which always includes the sterile closure screw. **WARNING** The internal vial consists of 3 parts. The cover screw (locking screw), if provided, is placed in the vial cap. Hold the vial upright to prevent the devices from leaking out. Unscrew the central part of the vial, to access the implant.



6

Some implant lines are supplied with mounting device connected to the implant, other lines are supplied without. Depending on the different configuration, use the appropriate instrument for the implant withdrawal from the vial and for the insertion of the same in the previously prepared implant site. The BTK dental implants can be positioned manually with the Reversible Torque Wrench or they can be inserted using the contra-angle handpiece. A range of 15 - 25 rpm is recommended for implant insertion and not to exceed the maximum torque indicated by BTK.

## IMPLANT INSERTION BT KONIC



The implant is supplied with the pre-assembled mounting device. The retentive screw of the mounting device is tightened to a constant value which preserves the correct positioning of the device on the implant thus avoiding accidental unscrewing. The tightening torque also guarantees the easy unscrewing of the device during the operating phase.

To withdraw the implant from the internal vial, use the handpiece wrench or a manual connection adapter. Insert the implant slowly in the previously prepared site. A range of 15-25 RPM is recommended.

During insertion, do not exceed the maximum torque values indicated below:

- **implants  $\leq \varnothing 3,7$  mm:**  
insertion torque max. 35 - 45 Ncm
- **implants  $> \varnothing 3,7$  mm:**  
insertion torque max. 45 - 65 Ncm



The mounting device reports six reference notches corresponding to the faces of the hexagon of the implant connection: it is advisable to place a notch in the vestibular position for correct reference during prosthetic planning. Follow this procedure even in the case of multiple implant placement.

If the implant does not reach the desired depth, do not force it, remove it from the site and repeat the milling and tapping operations, verifying the depth and the correct surgical sequence.



To manually insert the implant using the torque wrench, remove the handpiece retentive driver from the mounting device and apply the manual connection adapter previously inserted into the torque wrench.

For a correct use of the torque wrench refer to the dedicated section of the manual.



To remove the mounting device, use the 30° angled wrench, taking care about the correct positioning of the hexagon of the device itself. Holding the device fixed, unscrew the retentive screw with the appropriated screwdriver. Apply a slight axial force to the mounting device to remove it if the extraction of the device is difficult due to excessive tightening torque or due to the interference with the cortical bone.



In the cap of the internal vial is present, for each family of implants, the corresponding closure screw (cap screw), sterile and ready for use. Use a sterile saline solution to carefully clean the implant connection from any organic residues. Therefore, make sure that it is clean and dry, before placing the closure screw (cap screw) or any prosthetic components that have been decided to connect to the implant.

The closure screw is the chosen solution for the closed healing mode. To remove it more easily at the end of the healing period, a small amount of sterile vaseline or sterile chlorhexidine gel can be applied to the thread of the closure screw or healing cap before tightening it manually (5-8 Ncm) on the implant using a driver with a hexagonal connection.

It is advisable to perform a post-operative radiographic control.

## SIMPLICITY REDEFINED ONE KIT

The surgical tray is used for the secure storage and sterilization of surgical and auxiliary instruments of the BT KONIC system.

The surgical tray is made of a highly shock-proof thermoplastic, which is well established in medical applications and the material is suitable for frequent sterilization in the autoclave. General guidelines for the cleaning and sterilization are given in the corresponding "SURGICAL MANUAL" (Cod. 06201217).

### **SURGICAL KIT BT KONIC REF. 607NA009**





# REVERSIBLE TORQUE WRENCH

The Reversible Torque Wrench is a dismantable, multiple-use instrument that provides means of tightening implants, abutments and screws. The lever arm integrated in the Reversible Torque Wrench is pushed away from the main body to the desired torque value. A torque value indicator is mounted at 90° in relation to the lever arm and indicates different value marks.

## NOTE

Before the first and each following use, the Reversible Torque Wrench should be dismantled, cleaned, disinfected and sterilized in accordance with the instructions for use.

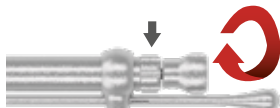

To dismantle the torque wrench for cleaning procedure, unscrew the wheel and then remove the inner bar where the spring is assembled.

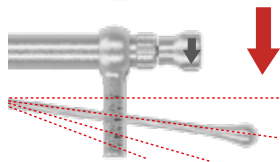

## APPLYING THE CORRECT TORQUE VALUE

In order to achieve the desired torque value, apply the force only to the lever-arm to the desired value mark. **The following marks are indicated: 15, 25, 35, 50, 70 and 90 Ncm.** Make sure that the arrow of the inversion device is matching to the lever-arm direction.



## HOW TO CHANGE DIRECTIONS

With this type of Reversible Torque Wrench, one is able to change directions by simply pulling (1) and turning (2) the inversion device 180° in the desired direction.



This is done without removing the Reversible Torque Wrench from the attached driver in order to avoid additional manipulations and to save time.

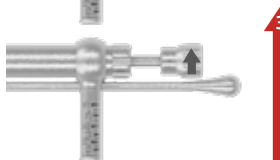

The grey arrow on the inversion device always indicates in which direction the force is applied (3). This design was chosen to avoid additional manipulation, reduce potential sources of error while helping to save time.



DEVICE	IMPLANT CONNECTION	MATERIAL	TIGHTENING TORQUE
Cover screw	-	Titanium GR5	from 5 to 8 Ncm ("hand tight")
Healing abutment	-	Titanium GR5	from 5 to 8 Ncm ("hand tight")
Impression Post screw, tightening to implant or implant replica	-	Titanium GR5	from 5 to 8 Ncm ("hand tight")
Retentive screw, tightening Scan Abutment	-	Titanium GR5	from 5 to 8 Ncm ("hand tight")
Retentive screw, temporary tightening (abutment to implant)	BP, BT, BU	Titanium GR5	from 10 to 15 Ncm
	AB, CB, CC, EA, KR, FA, IE, IF, IG, IH, CA, IA, IB, IC, ID, KB, QA, QB	Titanium GR5	from 15 to 20 Ncm
Retentive screw, final tightening (abutment to implant)	AC, DA, DB, EC, EN, ER, EW, IR, IM, IW, KA, KC, KW, SE, SR, TN, TR, TW	Titanium GR5	from 20 to 25 Ncm
	BP, BT, BU	Titanium GR5	from 10 to 15 Ncm
	CA, IA, IB, IC, ID, KB, QA, QB	Titanium GR5	from 20 to 25 Ncm
	AB, CB, CC, EA, KR, FA, IE, IF, IG, IH	Titanium GR5	from 25 to 30 Ncm
Straight abutment M.U.A.	AC, DA, DB, EC, EN, ER, EW, IR, IM, IW, KA, KC, KW, SE, SR, TN, TR, TW	Titanium GR5	from 30 to 35 Ncm
	EN, ER, EW, IR, IM, IW, TN, TR, TW	Pd-based Alloy*	from 30 to 35 Ncm
Abutment SOLID and OCTA	KR	Titanium GR5	from 25 to 30 Ncm
	EN, ER, IR, KW	Titanium GR5	from 30 to 35 Ncm
Retentive screw, tightening angled abutment M.U.A.	SR	Titanium GR5	from 30 to 35 Ncm
	KR	Titanium GR5	from 20 to 25 Ncm
Retentive screw, prosthesis to abutment M.U.A. - suprastructures	EN, ER, IR, KW	Titanium GR5	from 25 to 30 Ncm
	BT, BU, BP	Titanium GR5	from 10 to 15 Ncm
Locator® abutment to implant	-	Titanium GR5	from 20 to 25 Ncm
Lingual screw	-	Titanium GR5	10 Ncm
Retentive screw, tightening installation device to implant	-	Titanium GR5	12 Ncm
Implant installation with installation device. Implant Ø ≤ Ø 3,7 mm	-	-	from 35 to 45 Ncm
Implant installation with installation device. Implant Ø > 3,7 mm	-	-	from 45 to 65 Ncm

\* Composition: (%wt.): Pd bal., Ga 10%, Cu 7%, Au 2%, Zn 0.5%, Ir 0.3%, Ru 0.1%

## CHARACTERISTICS OF SURGICAL DRILLS

- All drills and screw taps are made of stainless steel.
- All drills and screw taps are supplied in non-sterile single packs or in kit not sterile. Please refer to the recommendations on cleansing and sterilization indicated by BTK.
- Drills and screw taps must be replaced after a maximum of 20 uses. The effectiveness decreases after 5/6 applications already.
- All drills and screw taps have depth markings made with laser technique.
- The length relative to the corresponding black strip, realized with laser technique, it is always the lower or upper end of the strip.
- The black strips correspond to the length of the selected implant. However, to increase safety, during the preparation of the site drill stops are recommended.
- All final drills allow to apply suitable drill stops using the Snap Fit fastening system.
- All drills report their diameter and the relevant reference code on the stem and the stops; there is also a black dot to identify the BT KLASSIC/ BT KONIC instruments.
- In case the length of the drills is insufficient, there is the possibility to connect them to the "Drill Extension" tool.

### SURGICAL STANDARDS

For successful osseointegration, a precise, not traumatic surgical technique is required, which safeguards the soft tissues and accurately prepares the implant site without overheating the bone.

Before starting the surgical procedure and during the same procedure the following points must be taken into account:

- Check that all the necessary tools are available and fully functional. It is recommended to always keep an adequate supply of sterile implants and instruments.
- Do not use cutting tools more than 20 times. Make sure that the drills are sharp before each use. The effectiveness of a drill already decreases after 5/6 applications.
- Drilling must be carried out with sharp drills always with abundant external irrigation with pre-cooled sterile saline solution and avoiding excessive pressures.
- Do not exceed the speeds indicated by BTK for drills.
- Use the drills with diameters in ascending order.
- The drills can be placed in distilled / deionized water but should not be placed in saline or Ringer's solution during surgery if they are used for more than one preparation.

TOOL	SPEED (RPM)
LANCE DRILL	800
TWIST DRILL (PILOT) Ø 2mm	800
DRILL Ø < 3.5mm	600
DRILL 3.5mm ≤ Ø ≤ 4.5mm	500
DRILL Ø > 4.5mm	400
COUNTERSINK	300/400

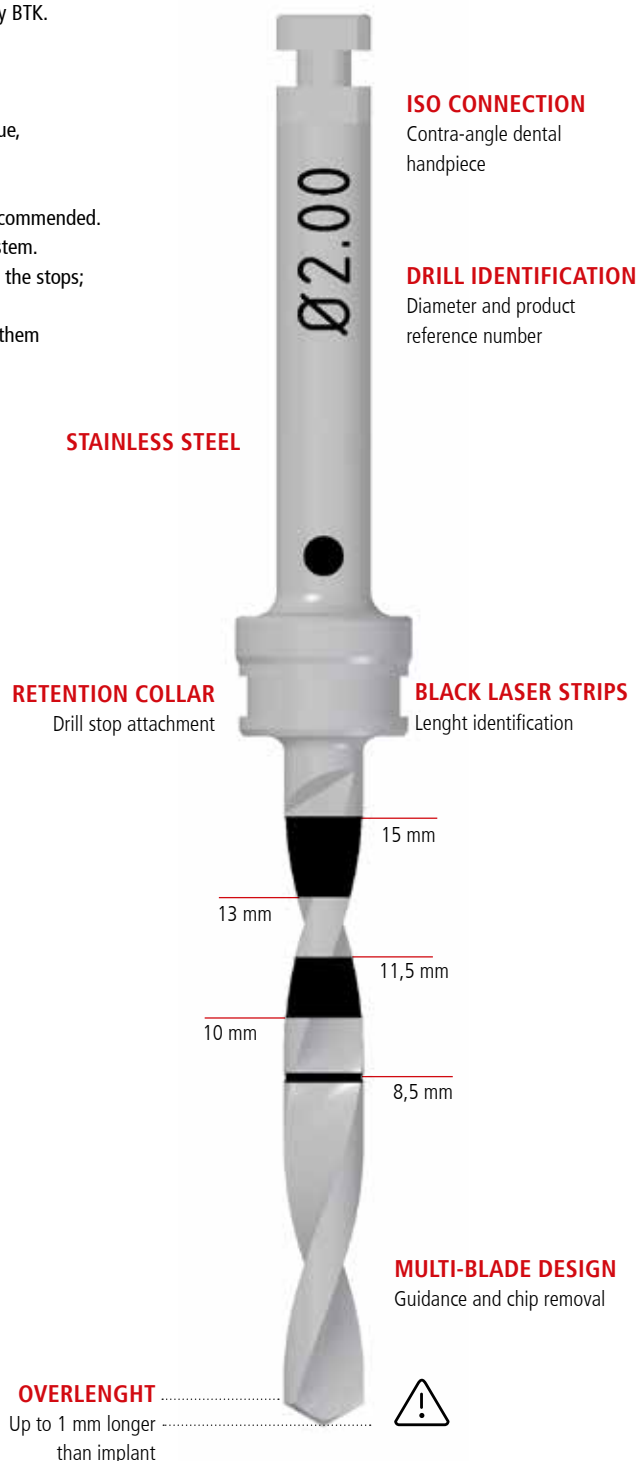



# SURGICAL PROTOCOL

IMPLANT		DRILLS								COUNTERSINKS			
		Sharp Lance Drill HR 401HR202	Drill (pilot) Ø 2 425HR200	Drill Ø 2,7 425HR270	Drill Ø 3 425HR300	Drill Ø 3,4 425HR340	Drill Ø 3,7 425HR370	Drill Ø 4,4 425HR440	Drill Ø 4,7 425HR470	Countersink Ø3,25 INT 433HS375	Countersink Ø3,25 EXT 433HS340	Countersink Ø4 433HS405 / 433HS405.R	Countersink Ø5 433HS500 / 433HS500.R
3,25	10mm INT												
	11,5mm INT	●	●	●	⊙					■			
	13mm INT	●	●	●	⊙								
	15mm INT												
4	10mm EXT												
	11,5mm EXT	●	●	●	⊙					■			
	13mm EXT	●	●	●	⊙								
	15mm EXT												
5	8,5mm												
	10mm												
	11,5mm	●	●	●	●	●	●	⊙	○				■
	13mm	●	●	●	●	●	●	⊙	○				
	15mm												

- Always
- ⊙ Only in presence of D1,D2 or D3 bone.
- Only in presence of D1-D2 bone.
- Only in presence of hard cortical bone

### N.B.





















The above procedures should be considered indicative; it is responsibility of the clinician to evaluate potential variations of the procedure on the basis of individual case and bone density. Due to the presence of cutting edges on drills, it is strongly recommended the use of the stop in order to avoid excessive depth of drilling that could compromise vital structures.





















































# SURGICAL INSTRUMENTS

























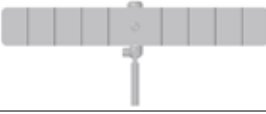

Contents of the BT KONIC Surgical Kit (Ref 607NA009) and optional instrumentation dedicated to the correct management of the surgical procedure.

PICTURE	REF	PRODUCT NAME	SPECIFICATION	INCLUDED IN THE KIT
<b>INITIAL PREPARATION</b>				
	401HS200	Round Drill HS	Ø2mm L30mm	
	401HS201	Lance Drill HS	Ø2mm L30mm	
	401HR202	Sharp Lance Drill HR	Ø2mm L33mm	✓
	540MA011	Depth Gauge	Ø1.8mm L108mm 30°	✓
	540MA006	Parallelism Pin	Ø2.3mm L21.5mm (4pcs)	✓
	540MA008	Depth Gauge	Ø2mm L31.5mm	
	520HS003	Drill Extension HS	L28mm	✓
<b>DRILLS, LENGHT 31.2 mm (SHORT)</b>				
	425HS200	Twist Drill HS	Ø2mm L31.2mm	
	425HS270	Twist Drill HS	Ø2.7mm L31.2mm	
	425HS300	Twist Drill HS	Ø3mm L31.2mm	
	425HS340	Twist Drill HS	Ø3.4mm L31.2mm	
	425HS370	Twist Drill HS	Ø3.7mm L31.2mm	
	425HS440	Twist Drill HS	Ø4.4mm L31.2mm	
	425HS470	Twist Drill HS	Ø4.7mm L31.2mm	
<b>DRILLS, LENGHT 35.2 mm (REGULAR)</b>				
	425HR200	Twist Drill HR	Ø2mm L35.2mm	✓
	425HR270	Twist Drill HR	Ø2.7mm L35.2mm	✓
	425HR300	Twist Drill HR	Ø3mm L35.2mm	✓
	425HR340	Twist Drill HR	Ø3.4mm L35.2mm	✓
	425HR370	Twist Drill HR	Ø3.7mm L35.2mm	✓
	425HR440	Twist Drill HR	Ø4.4mm L35.2mm	✓
	425HR470	Twist Drill HR	Ø4.7mm L35.2mm	✓

PICTURE	REF	PRODUCT NAME	SPECIFICATION	INCLUDED IN THE KIT
<b>COUNTERSINKS HS</b>				
	433HS340	Countersinks HS	Ø3.25mm L27mm BT KONIC Ext	✓
	433HS375	Countersinks HS	Ø3.25mm L27mm BT KONIC Int	✓
	433HS405	Countersinks HS	Ø4mm L27mm BT KONIC	✓
	433HS405.R	Countersinks HS	Ø4mm L27mm Reduced BT Konic	✓
	433HS500	Countersinks HS	Ø5mm L27mm BT KONIC	✓
	433HS500.R	Countersinks HS	Ø5mm L27mm Reduced BT Konic	✓
<b>AUXILIARY INSTRUMENTS</b>				
	501JD003	Torque Wrench JD, reversible	90Ncm	✓
	502MA002	Guide Shaft	Ø2.5mm	✓
	502MA003	Angled Wrench 30°	HEX3.10	✓
<b>DRILL STOPS Ø5 for REGULAR DRILLS ≤ Ø3.4mm</b>				
	690NA260	Kit Stop	Ø5 R7-15mm BT Klassic/ BT Evo/ BT Konic	
	522NA507	Drill Stop	H7mm Snap Fit	
	522NA508	Drill Stop	H8.5mm Snap Fit	✓
	522NA510	Drill Stop	H10mm Snap Fit	✓
	522NA511	Drill Stop	H11.5mm Snap Fit	✓
	522NA513	Drill Stop	H13mm Snap Fit	✓
	522NA515	Drill Stop	H15mm Snap Fit	✓
<b>DRILL STOPS Ø7 for REGULAR DRILLS ≥ Ø3.7mm</b>				
	690NA261	Kit Stop	Ø7 R7-15mm BT Klassic/ BT Evo/ BT Konic	
	522NA707	Drill Stop	H7mm Snap Fit	
	522NA708	Drill Stop	H8.5mm Snap Fit	✓
	522NA710	Drill Stop	H10mm Snap Fit	✓
	522NA711	Drill Stop	H11.5mm Snap Fit	✓
	522NA713	Drill Stop	H13mm Snap Fit	✓
	522NA715	Drill Stop	H15mm Snap Fit	✓



PICTURE	REF	PRODUCT NAME	SPECIFICATION	INCLUDED IN THE KIT
<b>DRILL STOPS Ø5 for SHORT DRILLS ≤ Ø3.6mm</b>				
	690NA262	Kit Stop	Ø5 S7-11.5mm BT Klassic/ BT Evo/ BT Konic	
	523NA507	Drill Stop	H7mm Snap Fit Short	
	523NA508	Drill Stop	H8.5mm Snap Fit Short	
	523NA510	Drill Stop	H10mm Snap Fit Short	
	523NA511	Drill Stop	H11.5mm Snap Fit Short	
<b>DRILL STOPS Ø7 for SHORT DRILLS ≥ Ø3.85mm</b>				
	690NA263	Kit Stop	Ø7 S7-11.5mm BT Klassic/ BT Evo/ BT Konic	
	523NA707	Drill Stop	H7mm Snap Fit Short	
	523NA708	Drill Stop	H8.5mm Snap Fit Short	
	523NA710	Drill Stop	H10mm Snap Fit Short	
	523NA711	Drill Stop	H11.5mm Snap Fit Short	
<b>HANDPIECE DRIVER</b>				
	530HS002	Handpiece Driver	HEX0.90 L25mm	
	530HS003	Handpiece Driver	HEX0.90 L30mm	
	530HS004	Handpiece Driver	HEX1.20 L25mm	
	530HS005	Handpiece Driver	HEX1.20 L30mm	
<b>IMPLANT DRIVER</b>				
IR-IW		530HS008	Implant Driver IR-IW	L30mm
		530HS009	Implant Driver IR-IW	L26mm
EN		530HS010	Implant Driver EN	L32mm
		530HS006	Implant Driver EN	L26mm
ER-EW		530HS011	Implant Driver ER-EW	L32mm
		530HS007	Implant Driver ER-EW	L26mm
<b>MOUNTING DEVICE</b>				
EN		690EN001	Mounting Device EN	L8mm
		690EN002	Mounting Device EN	L20mm
ER		690ER001	Mounting Device ER	L8mm
		690ER002	Mounting Device ER	L20mm
EW		690EW001	Mounting Device EW	L8mm
		690EW002	Mounting Device EW	L20mm









PICTURE	REF	PRODUCT NAME	SPECIFICATION	INCLUDED IN THE KIT	
<b>DISPOSITIVO DI MONTAGGIO</b>					
IR		690IR001	Mounting Device IR	L8mm	
		690IR002	Mounting Device IR	L20mm	
IW		690IW001	Mounting Device IW	L8mm	
		690IW002	Mounting Device IW	L20mm	
<b>RETENTIVE WRENCH</b>					
	530HS017	Retentive Wrench	HEX3.10	✓	
<b>HEX DRIVERS FOR MANUAL USE COMPATIBLE WITH REVERSIBLE TORQUE RATCHET (JD)</b>					
	530JD003	Screwdriver JD	HEX1.20 L5mm		
	530JD004	Screwdriver JD	HEX1.20 L10mm		
	530JD005	Screwdriver JD	HEX1.20 L15mm	✓	
	530JD006	Screwdriver JD	HEX1.20 L20mm		
	530JD007	Screwdriver JD	HEX1.20 L30mm		
	530JD011	Screwdriver JD	HEX0.90 L10mm		
	530JD012	Screwdriver JD	HEX0.90 L15mm	✓	
<b>ADAPTER CONNECTION</b>					
	530JD031	Adapter Connection	ISO/HEX3.10-JD L35mm		
	530JD032	Adapter Connection	ISO/HEX3.10-JD L7.5mm		
	530JD033	Adapter Connection	ISO/HEX3.10-JD L10mm	✓	
	530JD034	Adapter Connection	ISO/HEX3.10-JD L15mm		
<b>INSTRUMENTS FOR BT4 METHOD</b>					
	502MA006	Surgical Guide BT4	(PIN Ø2.5mm)		
	540MA007	Parallelism Pin	M1.4 L26mm		
	435EN001.02	Bone Profiler Guide EN	Kit 2pcs		
	435ER001.02	Bone Profiler Guide ER	Kit 2pcs		
	435IR001.02	Bone Profiler Guide IR	Kit 2pcs		
	435HS430	Bone Profiler HS	Ø4.3mm L25mm		
	530JD014	Screwdriver JD	HEX1.20 L15mm Reduced		
	530HS012	Handpiece Driver	HEX1.20 L30mm Reduced		
	530JD015	Screwdriver JD	HEX2.0 L5mm		
	530JD021	Screwdriver JD	HEX2.0 L10mm		
	530JD038	Screwdriver JD	HEX2.0 L20mm		













# INTERNAL HEXAGON (INT) IR/IW

## HEALING & SOFT TISSUE CONDITIONING





IR	IW	PICTURE	REF	PRODUCT NAME	SPECIFICATION
<b>HEALING ABUTMENTS</b>					
●			201IR2A0	Healing Abutment IR	H2mm Ø4.5mm
●			201IR3A0	Healing Abutment IR	H3mm Ø4.5mm
●			201IR4A0	Healing Abutment IR	H4mm Ø4.5mm
●			201IR4A1	Healing Abutment IR	H4mm Ø5.5mm
●			201IR5A0	Healing Abutment IR	H5mm Ø4.5mm
	●		201IW2A0	Healing Abutment IW	H2mm Ø6mm
	●		201IW3A0	Healing Abutment IW	H3mm Ø6mm
	●		201IW4A0	Healing Abutment IW	H4mm Ø6mm
	●		201IW5A0	Healing Abutment IW	H5mm Ø5.5mm

## IMPRESSION TAKING











IR	IW	PICTURE	REF	PRODUCT NAME	SPECIFICATION
<b>IMPRESSION POST</b>					
●			320IR0A1	Impression Post IR	Aluminium Cap
	●		320IW0 A1	Impression Post IW	Aluminium Cap
●	●		690NA029	Impression Post Caps	Aluminum Kit 3 pcs
●			325IR0A0	Impression Post Pro IR	Plastic Cap
	●		325IW0A1	Impression Post Pro IW	Plastic Cap
●	●		690NA091.10	Caps Kit Pro	Ø5.1mm Kit 10pcs
●	●		690NA068	Impression Post Screw	M1.8 HEX1.20 H7.9mm

IR	IW	PICTURE	REF	PRODUCT NAME	SPECIFICATION
<b>TRANSFER PICK-UP</b>					
●			323IR0A0	Impression Post Propick-Up IR	HUseful21.5mm Long screw
●			323IR0A1	Impression Post Propick-Up IR	HUseful16.5mm Short screw
●			323IR0R0	Impression Post Propick-Up IR	HUseful21.5mm Rotating Long screw
●			323IR0R1	Impression Post Propick-Up IR	HUseful16.5mm Rotating Short screw
	●		323IW0A0	Impression Post Propick-Up IW	HUseful21.5mm Long screw
	●		323IW0A1	Impression Post Propick-Up IW	HUseful16.5mm Short screw
	●		323IW0R0	Impression Post Propick-Up IW	HUseful21.5mm Rotating Long screw
	●		323IW0R1	Impression Post Propick-Up IW	HUseful16.5mm Rotating Short screw
●	●		690NA222	Impression Post Pick-Up Screw	M1.8 HEX1.20 H26mm
●	●		690NA190	Impression Post Pick-Up Screw	M1.8 HEX1.20 H21mm
<b>IMPLANT REPLICA</b>					
●			301IR0A1	Implant Replica IR	
	●		301IW0A1	Implant Replica IW	





















## INTERIM RESTORATIONS

IR	IW	PICTURE	REF	PRODUCT NAME	SPECIFICATION
<b>TEMPORARY ABUTMENTS</b>					
●			210IR2A0	Temporary Abutment IR	
●			210IR2A1	Temporary Abutment IR	Rotating
●			215IR2A0	Temporary Abutment IR	Peek
	●		210IW2A0	Temporary Abutment IW	
	●		210IW2R0	Temporary Abutment IW	Rotating
	●		215IW2A0	Temporary Abutment IW	Peek
●	●		690NA012	Retentive Screw	M1.8 HEX1.20

## CEMENT-RETAINED PROSTHESIS

IR	IW	PICTURE	REF	PRODUCT NAME	SPECIFICATION
<b>STRAIGHT ABUTMENTS</b>					
●			220IR0A0	Straight Abutment IR	H0mm Ø4.5mm
●			220IR2A1	Straight Abutment IR	H2mm Ø4.5mm
●			220IR3A0	Straight Abutment IR	H3mm Ø4.5mm
●			220IR4A0	Straight Abutment IR	H4mm Ø4.5mm
●			220IR5A0	Straight Abutment IR	H5mm Ø4.5mm
	●		220IW0A0	Straight Abutment IW	H0mm Ø5.5mm
	●		220IW2A0	Straight Abutment IW	H2mm Ø5.5mm
	●		220IW3A0	Straight Abutment IW	H3mm Ø5.5mm
	●		220IW4A0	Straight Abutment IW	H4mm Ø6mm
	●		220IW5A0	Straight Abutment IW	H5mm Ø5.5mm
●	●		690NA012	Retentive Screw	M1.8 HEX1.20
<b>ANGLED ABUTMENTS</b>					
●			220IR2D0	Angled Abutment IR	15° H2mm
●			220IR4D0	Angled Abutment IR	15° H4mm
●			220IR2F0	Angled Abutment IR	25° H2mm
●			220IR4F0	Angled Abutment IR	25° H4mm
	●		220IW2D0	Angled Abutment IW	15° H2mm
●	●		690NA012	Retentive Screw	M1.8 HEX1.20
<b>AESTHETIC ABUTMENTS</b>					
●			219IR0A0	Aesthetic Abutment IR	
	●		219IW0A0	Aesthetic Abutment IW	
●	●		690NA012	Retentive Screw	M1.8 HEX1.20
●	●		VLE14TIT	Lingual Screw Aesthetic Abut.	M1.4 HEX0.9

## SCREW-RETAINED / CEMENT-RETAINED PROSTHESIS

IR	IW	PICTURE	REF	PRODUCT NAME	SPECIFICATION
<b>BT LINK</b>					
●			246IR1A0	BT Link IR	H1mm Ø4.1mm
			246IR1A1	BT Link IR	H1mm Ø4.1mm Rotating
●			247IR1A0	BT Link IR	H1mm Ø4.1mm no Cap.
			247IR1A1	BT Link IR	H1mm Ø4.1mm no Cap. Rot
●			205NA001.05	Castable Plastic Abut. BT Link	H1mm Ø4.7mm Kit 5 pcs
	●		246IW1A0	BT Link IW	H1mm Ø5.6mm
			246IW1A1	BT Link IW	H1mm Ø5.6mm Rotating
	●		247IW1A0	BT Link IW	H1mm Ø5.6mm no Cap.
			247IW1A1	BT Link IW	H1mm Ø5.6mm no Cap. Rot
	●		205NA005.05	Castable Plastic Abut. BT Link	H1mm Ø5.6mm Kit 5 pcs
<b>CAST-ON TECHNIQUE</b>					
●			245IR1A0	Gold Abutment IR	H1mm
●			245IR1R0	Gold Abutment IR	H1mm Rotating
●			240IR1A0	CoCr Abutment IR	H1.5mm
			240IR1R0	CoCr Abutment IR	H1.5mm Rotating
	●		245IW1A0	Gold Abutment IW	H1mm
			245IW1R0	Gold Abutment IW	H1mm Rotating
	●		240IW1A0	CoCr Abutment IW	H1.5mm
			240IW1R0	CoCr Abutment IW	H1.5mm Rotating
<b>CASTABLE PLASTIC ABUTMENTS</b>					
●			205IR1A0	Castable Plastic Abutment IR	
●			205IR1A0.10	Castable Plastic Abutment IR	Kit 10pcs
●			205IR1A1	Castable Plastic Abutment IR	Rotating
			205IR1A1.10	Castable Plastic Abutment IR	Rotating Kit 10pcs
	●		205IW1A0	Castable Plastic Abutment IW	
			205IW1A0.10	Castable Plastic Abutment IW	Kit 10pcs
	●		205IW1R0	Castable Plastic Abutment IW	Rotating
			205IW1R0.10	Castable Plastic Abutment IW	Rotating Kit 10pcs
<b>RETENTIVE SCREWS</b>					
●	●		690NA012	Retentive Screw	M1.8 HEX1.20
●	●		690NA018	Retentive Screw Gold	M1.8 HEX1.20
●	●		690NA077	Retentive Screw BTK CAD-CAM	M1.8 HEX1.20 H7.8mm FH
<b>SCAN ABUTMENTS</b>					
●			351IR1A0	Scan Abutment Extra-oral IR	
●			352IR1A0	Scan Abutment Intra-oral IR	
	●		351IW1A0	Scan Abutment Extra-oral IW	
	●		352IW1A0	Scan Abutment Intra-oral IW	



## SCREW-RETAINED PROSTHESIS

IR	PICTURE	REF	PRODUCT NAME	SPECIFICATION
<b>BT4 STRAIGHT ABUTMENTS</b>				
●		265IR1R0	BT4 Straight Abutment IR	Rotating H1mm
		265IR2R0	BT4 Straight Abutment IR	Rotating H2mm
		265IR3R0	BT4 Straight Abutment IR	Rotating H3mm
<b>BT4 ANGLED ABUTMENTS</b>				
●		266IR2L0	BT4 Angled Abutment IR	17° H2mm Ø 4.8mm
		266IR3L0	BT4 Angled Abutment IR	17° H3mm Ø 4.8mm
		266IR3G0	BT4 Angled Abutment IR	30° H3mm Ø 4.8mm
<b>BT4 CAPS</b>				
●		690NA066	Retentive Screw BT4	M1.8 Angled Abutment IR-EN
		330NA0A0.04	Covering Caps BT4	H5 Kit 4pcs
		690NA024	Retentive Screw	M1.4 HEX1.20 10N
<b>BT4 INTERIM RESTORATION</b>				
●		267NA0A0	BT4 Titanium Abutment	
		207NA0A0	BT4 Castable Plastic Abutment	
		207NA0A1	BT4 Castable Plastic Abutment	no screw
		311NA0A0	BT4 Impression Post Pick-up	with long Screw
		690NA031	Impression Post Pick-Up Screw	M1.4 HEX1.20 H17mm
		303NA0A0	Abutment Replica BT4	
<b>BT4 SCAN ABUTMENT</b>				
●		351BT1A1	Scan Abutment Extra-oral BT	
		352BT1A1	Scan Abutment Intra-oral BT	
<b>BT4 BT LINK</b>				
●		246BT1A1	BT Link BT	H1mm Ø4.8mm Rotating
		247BT1A1	Base BT Link BT	H1mm Ø4.8mm no Cap. Rot.
		205NA003.05	Castable Plastic Abut. BT Link	H1mm Ø5.4mm Kit 5pcs
<b>BT4 CAST-ON TECHNIQUE</b>				
●		240BT1R0	CoCr Abutment BT	H1.5mm Rotating































# EXTERNAL HEXAGON (EXT) EN/ER/EW

## HEALING & SOFT TISSUE CONDITIONING







EN	ER	EW	PICTURE	REF	PRODUCT NAME	SPECIFICATION
<b>HEALING ABUTMENTS</b>						
●				201EN2A0	Healing Abutment EN	H2mm Ø4.5mm
●				201EN3A0	Healing Abutment EN	H3mm Ø4.5mm
●				201EN4A0	Healing Abutment EN	H4mm Ø4.5mm
●				201EN6A0	Healing Abutment EN	H6mm Ø4.5mm
	●			201ER2A0	Healing Abutment ER	H2mm Ø5mm
	●			201ER3A0	Healing Abutment ER	H3mm Ø5mm
	●			201ER4A0	Healing Abutment ER	H4mm Ø5mm
	●			201ER4A1	Healing Abutment ER	H4mm Ø6mm
	●			201ER4A2	Healing Abutment ER	H4mm Ø7.5mm
	●			201ER6A0	Healing Abutment ER	H6mm Ø5mm
	●			201ER6A1	Healing Abutment ER	H6mm Ø6mm
	●			201ER6A3	Healing Abutment ER	H6mm Ø7mm
	●			201ER8A0	Healing Abutment ER	H8mm Ø5mm
		●		201EW2A0	Healing Abutment EW	H2mm Ø6mm
		●		201EW3A0	Healing Abutment EW	H3mm Ø6mm
		●		201EW4A0	Healing Abutment EW	H4mm Ø6mm
		●		201EW4A1	Healing Abutment EW	H4mm Ø7.5mm
		●		201EW6A0	Healing Abutment EW	H6mm Ø6mm









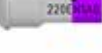

## IMPRESSION TAKING

EN	ER	EW	PICTURE	REF	PRODUCT NAME	SPECIFICATION
<b>IMPRESSION POST</b>						
●				320EN0A0	Impression Post EN	Aluminium Cap
	●			320ER0A1	Impression Post ER	Aluminium Cap
		●		320EW0A1	Impression Post EW	Aluminium Cap
●	●	●		690NA029	Impression Post Caps	Alluminium Kit 3pcs
●				325EN0A0	Impression Post Pro EN	Plastic Cap
	●			325ER0A0	Impression Post Pro ER	Plastic Cap
		●		325EW0A1	Impression Post Pro EW	Plastic Cap
●	●	●		690NA091.10	Caps Kit Pro	Ø5.1mm Kit 10pcs
●				690NA068	Impression Post Screw	M1.8 HEX1.20 H7.9mm
	●	●		690NA067	Impression Post Screw	M2 HEX1.20 H8.1mm
<b>IMPRESSION POST PROPICK-UP</b>						
●				323EN0A0	Impression Post Propick-Up EN	HUseful22.8mm Long screw
●				323EN0A1	Impression Post Propick-Up EN	HUseful17.8mm Short screw
●				323EN0R0	Impression Post Propick-Up EN	HUseful22.8mm Rotating Long screw
●				323EN0R1	Impression Post Propick-Up EN	HUseful17.8mm Rotating Short screw
●				690NA222	Vite Transfer Pick-Up	M1.8 HEX1.20 H26mm
●				690NA190	Vite Transfer Pick-Up	M1.8 HEX1.20 H21mm
	●			323ER0A0	Impression Post Propick-Up ER	HUseful21.5mm Long screw
	●			323ER0A1	Impression Post Propick-Up ER	HUseful16.5mm Short screw
	●			323ER0R0	Impression Post Propick-Up ER	HUseful21.5mm Rotating Long screw
	●			323ER0R1	Impression Post Propick-Up ER	HUseful16.5mm Rotating Short screw
		●		323EW0A0	Impression Post Propick-Up EW	HUseful21.5mm Long screw
		●		323EW0A1	Impression Post Propick-Up EW	HUseful16.5mm Short screw
		●		323EW0R0	Impression Post Propick-Up EW	HUseful21.5mm Rotating Long screw
		●		323EW0R1	Impression Post Propick-Up EW	HUseful16.5mm Rotating Short screw
	●	●		690NA223	Impression Post Pick-Up Screw	M2 HEX1.20 H24.4mm
	●	●		690NA191	Impression Post Pick-Up Screw	M2 HEX1.20 H19.4mm
<b>IMPLANT REPLICA</b>						
●				301EN0A0	Implant Replica EN	
	●			301ER0A1	Implant Replica ER	
		●		301EW0A0	Implant Replica EW	

## INTERIM RESTORATIONS





















EN	ER	EW	PICTURE	REF	PRODUCT NAME	SPECIFICATION
<b>TEMPORARY ABUTMENTS</b>						
●				210EN2A0	Temporary Abutment EN	
●				210EN2R0	Temporary Abutment EN	Rotating
●				215EN2A0	Temporary Abutment EN	Peek
	●			210ER2A0	Temporary Abutment ER	
	●			210ER2A1	Temporary Abutment ER	Rotating
	●			215ER2A0	Temporary Abutment ER	Peek
		●		210EW2A0	Temporary Abutment EW	
		●		210EW2R0	Temporary Abutment EW	Rotating
		●		215EW2A0	Temporary Abutment EW	Peek
●				690NA012	Retentive Screw	M1.8 HEX1.20
	●	●		690NA013	Retentive Screw	M2 HEX1.20

## CEMENT-RETAINED PROSTHESIS

EN	ER	EW	PICTURE	REF	PRODUCT NAME	SPECIFICATION
<b>STRAIGHT ABUTMENTS</b>						
●				220EN1A0	Straight Abutment EN	H1mm Ø4.5mm
●				220EN2A0	Straight Abutment EN	H2mm Ø4.5mm
●				220EN3A0	Straight Abutment EN	H3mm Ø4.5mm
●				220EN4A0	Straight Abutment EN	H4mm Ø4.5mm
	●			220ER2A1	Straight Abutment ER	H2mm Ø5mm
	●			220ER2A3	Straight Abutment ER	H2mm Ø6mm
	●			220ER2A2	Straight Abutment ER	H2mm Ø7.5mm
	●			220ER4A0	Straight Abutment ER	H4mm Ø5mm
	●			220ER4A1	Straight Abutment ER	H4mm Ø6mm
	●			220ER4A2	Straight Abutment ER	H4mm Ø7.5mm
		●		220EW2A2	Straight Abutment EW	H2mm Ø6mm
		●		220EW2A3	Straight Abutment EW	H2mm Ø7.5mm
		●		220EW4A2	Straight Abutment EW	H4mm Ø6mm
		●		220EW4A3	Straight Abutment EW	H4mm Ø7.5mm
●				690NA012	Retentive Screw	M1.8 HEX1.20
	●	●			690NA013	Retentive Screw
<b>ANGLED ABUTMENTS</b>						
●				220EN2D0	Angled Abutment EN	15° H2mm
●				220EN4D0	Angled Abutment EN	15° H4mm
●				220EN2F0	Angled Abutment EN	25° H2mm
●				220EN4F0	Angled Abutment EN	25° H4mm
	●			220ER2D0	Angled Abutment ER	15° H2mm
	●			220ER4D0	Angled Abutment ER	15° H4mm
	●			220ER2F0	Angled Abutment ER	25° H2mm
	●			220ER4F0	Angled Abutment ER	25° H4mm
		●		220EW2D0	Angled Abutment EW	15° H2mm
		●		220EW4D0	Angled Abutment EW	15° H4mm
		●		220EW2F0	Angled Abutment EW	25° H2mm
		●		220EW4F0	Angled Abutment EW	25° H4mm
●				690NA012	Retentive Screw	M1.8 HEX1.20
	●	●			690NA013	Retentive Screw















AESTHETIC ABUTMENTS						
●				219EN0A0	Aesthetic Abutment EN	
	●			219ER0A0	Aesthetic Abutment ER	
		●		219EW0A0	Aesthetic Abutment EW	
●				690NA012	Retentive Screw	M1.8 HEX1.20
	●	●		690NA013	Retentive Screw	M2 HEX1.20
●	●	●		VLE14TIT	Lingual Screw Aesthetic Abut.	M1.4 HEX0.9







### SCREW-RETAINED / CEMENT-RETAINED PROSTHESIS

EN	ER	EW	PICTURE	REF	PRODUCT NAME	SPECIFICATION
<b>BT LINK</b>						
●				246EN1A0	BT Link EN	H1mm Ø4.1mm
●				246EN1A1	BT Link EN	H1mm Ø4.1mm Rotating
●				247EN1A0	Base BT Link EN	H1mm Ø4.1mm no Cap.
●				247EN1A1	Base BT Link EN	H1mm Ø4.1mm no Cap. Rot
●				205NA001.05	Castable Plastic Abut. BT Link	H1mm Ø4.7mm Kit 5 pcs
	●			246ER1A0	BT Link ER	H1mm Ø4.6mm
	●			246ER1A1	BT Link ER	H1mm Ø4.6mm Rotating
	●			247ER1A0	Base BT Link ER	H1mm Ø4.6mm no Cap.
	●			247ER1A1	Base BT Link ER	H1mm Ø4.6mm no Cap. Rot
	●			205NA002.05	Castable Plastic Abut. BT Link	H1mm Ø5.2mm Kit 5 pcs
		●		246EW1A0	BT Link EW	H1mm Ø5.6mm
		●		246EW1A1	BT Link EW	H1mm Ø5.6mm Rotating
		●		247EW1A0	Base BT Link EW	H1mm Ø5.6mm no Cap.
		●		247EW1A1	Base BT Link EW	H1mm Ø5.6mm no Cap. Rot
		●		205NA005.05	Castable Plastic Abut. BT Link	H1mm Ø5.6mm Kit 5 pcs
<b>CAST-ON TECHNIQUE</b>						
●				245EN1A0	Gold Abutment EN	H1mm
●				245EN1R0	Gold Abutment EN	H1mm Rotating
●				240EN1A0	CoCr Abutment EN	H1.5mm
●				240EN1R0	CoCr Abutment EN	H1.5mm Rotating
	●			245ER1A0	Gold Abutment ER	H1mm
	●			245ER1R0	Gold Abutment ER	H1mm Rotating
	●			240ER1A0	CoCr Abutment ER	H1.5mm
	●			240ER1R0	CoCr Abutment ER	H1.5mm Rotating
		●		245EW1A0	Gold Abutment EW	H1mm
		●		245EW1R0	Gold Abutment EW	H1mm Rotating
		●		240EW1A0	CoCr Abutment EW	H1.5mm
		●		240EW1R0	CoCr Abutment EW	H1.5mm Rotating
<b>CASTABLE PLASTIC ABUTMENTS</b>						
●				205EN1A1	Castable Plastic Abutment EN	
●				205EN1A1.10	Castable Plastic Abutment EN	Kit 10pcs
●				205EN1R1	Castable Plastic Abutment EN	Rotating
●				205EN1R1.10	Castable Plastic Abutment EN	Rotating Kit 10pcs
	●			205ER2A0	Castable Plastic Abutment ER	
	●			205ER2A0.10	Castable Plastic Abutment ER	Kit 10pcs
	●			205ER2A1	Castable Plastic Abutment ER	Rotating
	●			205ER2A1.10	Castable Plastic Abutment ER	Rotating Kit 10pcs
		●		205EW2A0	Castable Plastic Abutment EW	
		●		205EW2A0.10	Castable Plastic Abutment EW	Kit 10pcs
		●		205EW2A1	Castable Plastic Abutment EW	Rotating
		●		205EW2A1.10	Castable Plastic Abutment EW	Rotating Kit 10pcs

RETENTIVE SCREWS						
●				690NA012	Retentive Screw	M1.8 HEX1.20
	●	●		690NA013	Retentive Screw	M2 HEX1.20
●				690NA018	Retentive Screw Gold	M1.8 HEX1.20
	●	●		690NA019	Retentive Screw Gold	M2 HEX1.20
●				690NA077	Retentive Screw BTK	M1.8 HEX1.20 H7.8mm FH
	●	●		690NA076	Retentive Screw BTK	M2 HEX1.20 H7.5mm FH
SCAN ABUTMENTS						
●				351EN1A0	Scan Abutment Extra-oral EN	
●				352EN1A0	Scan Abutment Intra-oral EN	
	●			351ER1A0	Scan Abutment Extra-oral ER	
	●			352ER1A0	Scan Abutment Intra-oral ER	
		●		351EW1A0	Scan Abutment Extra-oral EW	
		●		352EW1A0	Scan Abutment Intra-oral EW	

### SCREW-RETAINED PROSTHESIS

EN	ER	PICTURE	REF	PRODUCT NAME	SPECIFICATION
BT4 STRAIGHT ABUTMENTS					
●			265EN1R0	BT4 Straight Abutment EN	Rotating H1mm
●			265EN2R0	BT4 Straight Abutment EN	Rotating H2mm
●			265EN3R0	BT4 Straight Abutment EN	Rotating H3mm
	●		265ER1R0	BT4 Straight Abutment ER	Rotating H1mm
	●		265ER2R0	BT4 Straight Abutment ER	Rotating H2mm
	●		265ER3R0	BT4 Straight Abutment ER	Rotating H3mm
BT4 ANGLED ABUTMENTS					
●			266EN2L0	BT4 Angled Abutments EN	17° H2mm Ø 4.8mm
●			266EN3L0	BT4 Angled Abutments EN	17° H3mm Ø 4.8mm
●			266EN3G0	BT4 Angled Abutments EN	30° H3mm Ø 4.8mm
	●		266ER2L0	BT4 Angled Abutments ER	17° H2mm Ø 4.8mm
	●		266ER3L0	BT4 Angled Abutments ER	17° H3mm Ø 4.8mm
	●		266ER3G0	BT4 Angled Abutments ER	30° H3mm Ø 4.8mm
BT4 CAPS					
●			690NA066	Retentive Screw	M1.8 Angled abutment IR-EN
	●		690NA065	Retentive Screw BT4	M2 Angled abutment ER
●	●		330NA0A0.04	Covering Caps BT4	H5 Kit 4pcs
●	●		690NA024	Retentive Screw	M1.4 HEX1.20 10N
INTERIM RESTORATION BT4					
●	●		267NA0A0	BT4 Titanium Abutment	
●	●		207NA0A0	BT4 Castable Plastic Abutment	
●	●		207NA0A1	BT4 Castable Plastic Abutment	no screw
●	●		311NA0A0	Impression Post Pick-up BT4	with long Screw
●	●		690NA031	Impression Post Pick-Up Screw	M1.4 HEX1.20 H17mm
●	●		303NA0A0	Abutment Replica BT4	

EN	ER	PICTURE	REF	PRODUCT NAME	SPECIFICATION
<b>BT4 SCAN ABUTMENT</b>					
●	●		351BT1A1	Scan Abutment Extra-oral BT	
			352BT1A1	Scan Abutment Intra-oral BT	
<b>BT4 BT LINK</b>					
●	●		246BT1A1	BT Link BT	H1mm Ø4.8mm Rotating
			247BT1A1	Base BT Link BT	H1mm Ø4.8mm no Cap. Rot.
			205NA003.05	Castable Plastic Abut. BT Link	H1mm Ø5.4mm Kit 5pcs
<b>BT4 CAST-ON TECHNIQUE</b>					
●	●		240BT1R0	CoCr Abutment BT	H1.5mm Rotating





# OVERDENTURE

## SPHERO®



	SPHERO® Block Normo Sphere Ø 2.5mm		SPHERO® Block Micro Sphere Ø 1.8mm		SPHERO® Flex Sphere Ø 2.5mm 0°-7.5° Divergence	
	REF	SPECIFICATION	REF	SPECIFICATION	REF	SPECIFICATION
IR	254IR1A0	H1mm	255IR1A0	H1mm	256IR1A0	H1mm
	254IR2A0	H2mm	255IR2A0	H2mm	256IR2A0	H2mm
	254IR3A0	H3mm	255IR3A0	H3mm	256IR3A0	H3mm
	254IR4A0	H4mm	255IR4A0	H4mm	256IR4A0	H4mm
	254IR5A0	H5mm	255IR5A0	H5mm	256IR5A0	H5mm
	254IR6A0	H6mm	255IR6A0	H6mm	256IR6A0	H6mm
	254IR7A0	H7mm	255IR7A0	H7mm	256IR7A0	H7mm
IW	254IW1A0	H1mm	255IW1A0 255IW2A0 255IW3A0 255IW4A0	H1mm	256IW1A0 256IW2A0 256IW3A0	H1mm
	254IW2A0	H2mm		H2mm		H2mm
	254IW3A0	H3mm		H3mm		H3mm
	254IW4A0	H4mm		H4mm		
	254IW5A0	H5mm				
	254IW6A0	H6mm				
	254IW7A0	H7mm				
EN	254EN1A0	H1.4mm	255EN1A0	H1mm	256EN1A0	H1mm
	254EN2A0	H2mm	255EN2A0	H2mm	256EN2A0	H2mm
	254EN3A0	H3mm	255EN3A0	H3mm	256EN3A0	H3mm
	254EN4A0	H4mm	255EN4A0	H4mm	256EN4A0	H4mm
	254EN5A0	H5mm	255EN5A0	H5mm	256EN5A0	H5mm
	254EN6A0	H6mm	255EN6A0	H6mm	256EN6A0	H6mm
	254EN7A0	H7mm	255EN7A0	H7mm	256EN7A0	H7mm
ER	254ER1A0	H1mm	255ER1A0	H1mm	256ER1A0	H1mm
	254ER2A0	H2mm	255ER2A0	H2mm	256ER2A0	H2mm
	254ER3A0	H3mm	255ER3A0	H3mm	256ER3A0	H3mm
	254ER4A0	H4mm	255ER4A0	H4mm	256ER4A0	H4mm
	254ER5A0	H5mm	255ER5A0	H5mm	256ER5A0	H5mm
	254ER6A0	H6mm	255ER6A0	H6mm	256ER6A0	H6mm
	254ER7A0	H7mm	255ER7A0	H7mm	256ER7A0	H7mm
EW	254EW1A0	H1MM	255EW1A0	H1MM	256EW1A0	H1MM
	254EW2A0	H2MM	255EW2A0	H2MM	256EW2A0	H2MM
	254EW3A0	H3MM	255EW3A0	H3MM	256EW3A0	H3MM
	254EW4A0	H4MM	255EW4A0	H4MM	256EW4A0	H4MM
	254EW5A0	H5MM	255EW5A0	H5MM	256EW5A0	H5MM
	254EW6A0	H6MM	255EW6A0	H6MM	256EW6A0	H6MM
	254EW7A0	H7MM	255EW7A0	H7MM	256EW7A0	H7MM

### Accessories Sphero®

PICTURE	REF	PRODUCT NAME	SPECIFICATION
	530JD030	Wrench Driv. Sphero Block/Flex	Rhein83®771CEF

**NOTA** Every SPHERO® as listed above includes the following products: 1pc. Titanium Abutment with self-aligning 2.5mm or 1.8 mm sphere, 2pcs. Soft Retention Pink Caps, 1pc. Stainless Steel Housing, 1pc. Protective Disk and 3 pcs. Directional Rings.

These Devices are produced by Rhein83. s.r.l. Via E. Zago, 10/ABC, 40128 Bologna Italy.



Abutment Locator®					
IR		ER		EW	
REF	SPECIFICATION	REF	SPECIFICATION	REF	SPECIFICATION
260IR0A0	H0,63mm	260ER1A0	H1mm	260EW1A0	H1mm
260IR1A0	H1mm	260ER2A0	H2mm	260EW2A0	H2mm
260IR2A0	H2mm	260ER3A0	H3mm	260EW3A0	H3mm
260IR3A0	H3mm	260ER4A0	H4mm	260EW4A0	H4mm
260IR4A0	H4mm	260ER5A0	H5mm	260EW5A0	H5mm
260IR5A0	H5mm	260ER6A0	H6mm		
260IR6A0	H6mm				

Locator® Accessories			
PICTURE	REF	PRODUCT NAME	SPECIFICATION
	540MA015	Angle Meas. Guide Locator®	
	540MA016.04	Parallel Pin for Locator®	Kit 4pcs
	321NA0A0	Impression Post Locator®	
	301NA0A0	Implant Replica Locator® Abut.	
	690NA011	Replacement Males Locator®	
	690NA022	Kit Locator®	Metal Cap + Blockout Spacer
	690NA054.04	Replacement Males Locator®	0N Black Kit 4pcs
	690NA006.04	Replacement Males Locator®	15N Blue Kit 4pcs (700gr. 0-20°)
	690NA008.04	Replacement Males Locator®	30N Pink Kit 4pcs (1400gr. 0-20°)
	690NA010.04	Replacement Males Locator®	50N Neutral Kit 4pcs (2300gr. 0-20°)
	690NA005.04	Replacement Males Locator®	10N Red Kit 4pcs (700gr. 20-40°)
	690NA007.04	Replacement Males Locator®	20N Orange Kit 4pcs (900gr. 20-40°)
	690NA009.04	Replacement Males Locator®	40N Green Kit 4pcs (1400gr. 20-40°)
	690NA134.04	Replacement Males Locator®	0N Gray Kit 4pcs (0gr.)
	502MA004	Locator® Core Tool 3 in 1	
	502MA019	Locator® Male Removal Tip End	
	530HS015	Handpiece Driver Locator®	L 23mm
	530HS016	Handpiece Driver Locator®	L 29mm
	690NA020	Retaining Sleeve Locator®	Locator® core tool
	530JD029	Screwdriver JD Locator	L10mm (for reversible torque wrench JD)

**NOTA** Every "LOCATOR® Abutment" as listed above includes the following products: 1 pc. LOCATOR® Abutment; 1 pc. Denture Male Cap (Housing); 1 pc. Block-Out Spacer, 1 pc. each LOCATOR® Replacement Males (blue / pink / clear). All these codes (except 530JD029) are medical devices patented and realised by Zest Anchors Inc, 2061 Wineridge Place, Escondido CA 92029 USA. LOCATOR® is a registered trademark of Zest Anchors Inc.

## MATERIAL SPECIFICATIONS

### TITANIUM GRADE 4 IMPLANTS

CHEMICAL COMPOSITION:	MAXIMUM VALUES (%)	TOLERANCE
Nitrogen (N)	0.05	+/- 0.02
Carbon (C)	0.08	+/- 0.02
Hydrogen (H)	0.015	+/- 0.002
Iron (Fe)	0.50	+/- 0.10 (%<0.25) +/- 0.15 (%>0.25)
Oxygen (O)	0.40	+/- 0.02 (%<0.20) +/- 0.03 (%>0.20)
Titanium (Ti)	balance	-

MECHANICAL PROPERTIES:	MINIMUM VALUES
Tensile stress:	550 MPa
Yield strength (0.2%):	483 MPa
Elongation at yield:	15 %
Section reduction:	25 %

This technical information complies with the express specification of the regulations in force for the use of grade 4 titanium in implantology:

- ASTM F67: Standard Specification for unalloyed titanium, for surgical implant applications.
- ISO 5832-2: Implant for surgery – Metallic Materials – Part 2: Unalloyed titanium.

### TITANIUM GRADE 5 PROSTHETICS AND MINI IMPLANTS

CHEMICAL COMPOSITION:	MAXIMUM VALUES (%)	TOLERANCE
Nitrogen (N)	0.05	+/- 0.02
Carbon (C)	0.08	+/- 0.02
Hydrogen (H)	0.012	+/- 0.002
Iron (Fe)	0.25	+/- 0.10
Oxygen (O)	0.13	+/- 0.02
Aluminium (Al)	5.50-6.50	+/- 0.40
Vanadium (V)	3.50-4.50	+/- 0.15
Titanium (Ti)	balance	-

MECHANICAL PROPERTIES:	MINIMUM VALUES
Tensile stress:	860 MPa
Yield strength (0.2%):	795 MPa
Elongation at yield:	10 %
Section reduction:	25 %

This technical information complies with the express specification of the regulations in force for the use of grade 5 titanium in implantology:

- ASTM F136: Standard Specification for wrought Titanium-6Aluminium-4Vanadium ELI (Extra low Interstitial) Alloy for surgical implant applications;
- ISO 5832-3: Implant for surgery – Metallic Materials – Part 3: Wrought titanium 6-aluminium 4-vanadium alloy.

### COBALT CHROME COBALT CCM®

CHEMICAL COMPOSITION: (%)	
Carbon (C)	max. 0.14
Silicon (Si)	max. 1.00
Manganese (Mn)	max. 1.00
Chromium (Cr)	26.00-30.00
Molybdenum (Mo)	5.00-7.00
Nickel (Ni)	max. 1.0
Iron (Fe)	max. 0.75
Nitrogen (N)	max. 0.25
Cobalt (Co)	balance

MATERIAL NO. AND NORMS	
DIN	CoCr28Mo
ISO	5832-12
AFNOR	CoCr28Mo
ASTM	F1537 alloy 1
UNS	R31537

MECHANICAL PROPERTIES	
Coefficient of Expansion (CTE)	13.2•10 <sup>-6</sup> °C <sup>-1</sup>
Melting range	1340-1440°C
Yield strength (R0.2)	up to 1115 MPa
Young Modulus E	241 GPa
Hardness	up to 46 HRC



## PRECIOUS ALLOY FOR ABUTMENTS

COMPOSITION:	
Gold (Au)	60.0 %
Platinum (Pt)	24.9 %
Palladium (Pd)	15.0 %
Iridium (Ir)	0.1 %
PHYSICAL AND MECHANICAL PROPERTIES:	
Density:	18.1 g/cm <sup>3</sup>
Melting range:	1350 – 1460 °C
Coefficient of Expansion (CTE) 25-500°C – 25-600°C:	12.7•10 <sup>-6</sup> °C <sup>-1</sup> – 12.9•10 <sup>-6</sup> °C <sup>-1</sup>
Modulus of elasticity (tensile test):	110 GPa
Elongation at yield:	18 – 12 %
Breaking load:	580 – 810 MPa
Yield strength (0.2%):	450 – 720 MPa
Vickers Hardness HV5/30:	150 – 205 – 230

## PRECIOUS ALLOY FOR GOLD RETENTIVE SCREWS

COMPOSITION:	MAXIMUM VALUES (%)	TOLERANCE
Gold (Au)	0,5	+/- 0.2
Gallium (Ga)	2	+/- 0.2
Copper (Cu)	10	+/- 0.5
Iridium (Ir)	7	+/- 0.5
Ruthenium (Ru)	0.03	+/- 0.02
Rutenio (Ru)	0.1	+/- 0.09
Palladium (Pd)	balance	
MECHANICAL PROPERTIES:	MINIMUM VALUES (%)	
Tensile stress:	586 - 862 MPa	
Yield strength (0.2%):	483 - 690 MPa	
Elongation:	5 - 20 %	
Young's Modulus:	138 GPa	
PHYSICAL PROPERTIES:		
Melting Range	1450 – 1500 °C	
Coefficient of Expansion (CTE) 25-500°C – 25-600°C:	12.3•10 <sup>-6</sup> °C <sup>-1</sup>	

The temporary abutments in PEEK and the SCAN ABUTMENT are made of PEEK / TECAPEEK CLASSIC (chemical name Polietereeterketone). This material is suitable to stay in contact with tissue for up to 180 days.

Depending on the intended use, the Biotec instrumental is made of specific types of stainless steel.

## SYMBOLS USED ON LABELS



Legal manufacturer



Use-by date: indicates the date after which this device is not to be used



Products with the CE mark in accordance with Directive 93/42/EEC and following modifications/integrations



Do not use if packaging is damaged



0426  
Number of the notification body



Do not reuse



Consult instructions for use



Keep away from sunlight



[ifu.btk.dental](http://ifu.btk.dental)

Electronic instructions for use available online [ifu.btk.dental](http://ifu.btk.dental)



Sterile by gamma irradiation



Caution; see instructions for use



Catalogue number



Lot/batch number

## DELIVERY TERMS & CONDITIONS

### RESPONSABILITY

The use of BTK medical devices is reserved exclusively for personnel with the necessary qualifications for the exercise. An improper or incorrect use of the devices can cause the failure or worse, injury to the patient or the user. BTK implant systems should only be used with original BTK components and instruments and in accordance with the specific BTK instructions. Combining with different devices may cause a failure. Biotec must not and can not control the procedures for using the product for implant-prosthetic treatment. Therefore, Biotec assumes no responsibility for the application of the device and its processing nor for any incongruous use of the device under the surgical or prosthetic profile, nor in any case for failure, adverse reactions or damage to the patient or dentist as a result of application of the product.

### STERILITY OF WARRANTY AND DISPOSABLE

Dental implants are supplied STERILE (gamma ray sterilization). The sterility of the medical implant is guaranteed only according to the following conditions: the expiry date stated on the packaging is still valid; there is a red dot on the sterile vial which demonstrates that it has undergone gamma ray irradiation; the sealed package has not been opened and does not show any signs of damage. Compliance with all these conditions must be ensured; alternatively do not use the device.

Surgical components, laboratory accessories and instruments are not supplied in sterile packs, therefore before use they must be properly CLEANED and STERILIZED, as shown in the instructions for use. Biotec dental implants, prosthetics and laboratory accessories are designed for SINGLE USE. In fact, reuse is a potential risk and could damage the construction of the device, making it inappropriate for its intended use. Biotec explicitly declares the single-use of MD and assumes no responsibility for any re-use by users.

### STORAGE

Biotec products must be stored at room temperature and protected from direct heat or sunlight and dust.

### INSTRUCTIONS FOR USE

The information in this manual is not intended to be exhaustive for BTK implant systems. It is recommended that new customers follow the training courses that Biotec makes available with trained personnel and clinicians who are experts in implantology and in the use of BTK devices. The complete and updated user manuals, which allow the correct use of the product, are available online ([www.btk.dental](http://www.btk.dental)) or at BTK and / or the local distributor.

### AVAILABILITY

Not all products described here are available in ExtraEU countries. For more information, please contact BTK and / or your local distributor.

### RETURNS

Biotec does not accept returned goods if the packaging seals are broken or not conforming to the sale specifications of the company.

### GUARANTEE

We constantly guarantee that the quality of our products and services meets the high expectations of our customers and their patients. Specialized professionals are committed to offering complete solutions in applied research, engineering, training and related activities. Biotec is available to customers in the event that a defect in the product or its use is found.

### VALIDITY

The contents are updated at the date of publication. This manual replaces all previous editions.

### CASE DOCUMENTATION AND TRACEABILITY

BTK absolutely recommends documenting implant cases comprehensively at the clinical, radiographic, photographic and statistical levels. The clinician must guarantee the traceability of the devices used. It is advisable to use the adhesive labels included in the packaging of the BTK devices, which show the code and lot of the device used, for the purpose of documentation on the medical records and on the relative implant passport of the patient.

### TRAINING

Comprehensive and regular training ensures long-term implant success.

Be advised that we strongly recommend regular education events in order to update your know-how and clinical expertise.

### DELIVERY TERMS

BTK delivery terms are 1 working day for order received before 12.00 p.m. of the previous day in Italy; except for islands where delivery is evaluated to be 2 working days. For export deliveries contact Biotec offices.

### QUALITY STANDARD

Owing to extensive research, development and to a strict quality standard, we guarantee premium quality materials and products. Our products meet the requirements of directive 93/42 /EEC and subsequent amendments and additions, and therefore have the CE mark, in accordance with the corresponding law. BTK has a quality system certified UNI EN ISO 9001 and UNI EN ISO 13485.

### CAUTION

In addition to the instructions for use, warnings and risks reported both in this document and in the instructions for use, it must always be ensured that the devices used in the oral cavity are not aspirated or swallowed by the patient.

### COPYRIGHT AND TRADEMARKS

BTK documents cannot be reprinted or published, in whole or in part, without the written permission of BTK.

BTK, BIOTEC, The Smile System® or Implanting Trust, Smile Again® are trademarks or registered trademarks of BIOTEC s.r.l. and / or its affiliates.









### **BTK PERSONAL TUTOR**

A program for individual case planning and execution supported by experienced professionals in order to leverage know-how and maximize clinical experience with the aim to achieve sustainable high patient satisfaction rates.

**BTK is always at your disposal for any request for further follow-up or information, promoting periodic and ad-hoc training course.**

### **CERTIFIED QUALITY SYSTEM**

BIOTEC is certified UNI EN ISO 9001  
and UNI EN ISO 13485.



CE marked product, in accordance with Directive 93/42/EEC and subsequent modifications and additions.

### **MADE IN ITALY USED GLOBALLY**



We constantly ensure that the quality of our products and services meet the high expectations of our customers and their patients.

Specialized professionals are taking care to offer comprehensive solutions in applied research, engineering, education and related activities.

